

INSTALLATION AND OPERATING INSTRUCTION
Electronic Roller Door Lock **YR10**

CONTENTS

• DESCRIPTION	2
• PRODUCT UNBOXED	2
• PRE - INSTALLATION ASSESMENT	2
○ Mechanical	2
○ Electrical	3
• INSTALLATION	4
○ Mark the lock position	4
○ Drill the lock mounting holes	4
○ Secure the lock in position	4
○ Mark the strikes position	4
○ Drill the strikes mounting holes	5
○ Secure the strike in position	5
○ Wire the lock	5
○ Cover the lock	5
• WIRING	6
• OPERATING CONFIGURATION	6
○ Fail State	7
○ Auto re-lock	7
○ Timed re-lock	7
○ Diagnostic mode	7
• OPERATION	7
○ Auto re-lock ON	8
○ Auto re-lock OFF	8
○ General	9
○ Alarms	9
• SPECIFICATIONS	10
• DIMENSIONS	10
○ Lock	10
○ Strike	11
• MAINTENANCE	11
• WARRANTY	11
• UPGRADE	11

1. DESCRIPTION

The YR10 is a low voltage motor driven lock suited for securing large rolling, tilting, hinged or sliding doors and shutters. It is supplied with a matching strike plate and can be installed internally in a horizontal or vertical position. A solid 18mm diameter stainless steel bolt pin ensures the highest strength while a bolt pin extension of 35mm offers flexible installation.

Integrated electronics provide complete control over the lock and offer an array of features;

- Multi-voltage input (12-24VDC)
- Multiple locking / unlocking attempts to correct miss-aligned doors
- Selectable automatic locking when the door closes
- Fail safe / Fail secure user selection with a single switch
- Door position monitoring
- Bolt locked and Bolt unlocked monitors

The lock incorporates a keyed manual override and wiring can be run securely through the locks base or externally through a 20mm wiring gland.

2. PRODUCT UNBOXED



Lock Cover with two keys

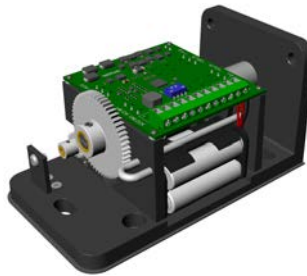

Lock



Lock Mounting Bolts



Strike

Because of the various fitting locations of the YR10, **no mounting bolts are supplied for the strike**. The mounting holes in the strike are 8.5mm slotted holes so accept M8 size bolts.

3. PRE - INSTALLATION ASSESMENT

3.1 Mechanical

Before the lock can be installed, consider its location and orientation. The lock is commonly placed on the ground and secured using the **supplied** mounting bolts; however it can readily be mounted to a wall by choosing the appropriate bolts / screws (**not supplied**). The strike will be fitted to the door again by selecting and using the appropriate bolts / screws (**not supplied**).

When positioning the strike, it is important to achieve a reasonable level of alignment with the bolt pin as to ensure correct locking and operation. The hole in the strike is of significantly larger diameter than that of the lock pin, however installing the strike so the lock pin goes into the hole centrally is best as it will allow for movement of the door over time.

There are three magnets in the strike which offers the flexibility of mounting options and with the symmetrical design of the lock, the strike can approach from either the right, left or bottom face of the lock as shown below.

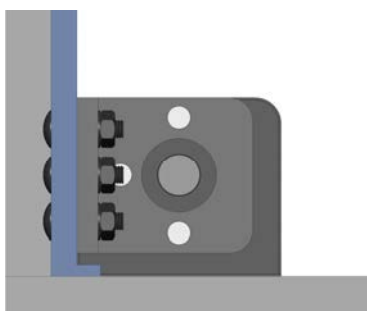

Lock fitted to the floor, strike bolted to the door on the left.

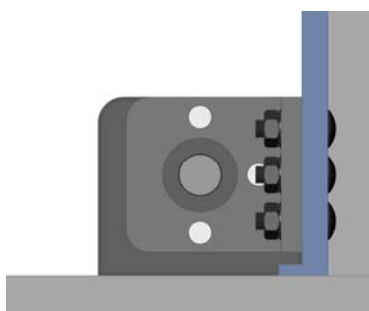

Lock fitted to the floor, strike bolted to the door on the right.

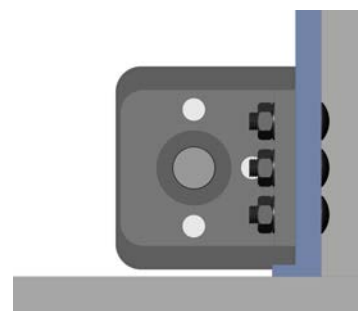

Lock mounted to the wall, strike bolted to the door on the right.

3.2 Electrical

After the positions of the lock and strike are determined, establish where to run the wires and also decide on what feedback is required from the lock. There are a total of eleven available connections on the lock; three are compulsory and eight are optional.

The three essential connections are; Positive (+), Negative (-) and Control (CL). There need to be wires run from the power source and control switch to the lock.

The eight optional connections all provide feedback about the locks state; Door Position, Bolt Locked Position and Bolt Unlocked Position. If desired, wires can be run from these connections to integrate into access control or alarm systems to provide full monitoring.

Once the number of wires and their destination is determined, it needs to be decided how the wires will enter the lock. They can either come in through a 20mm wiring gland at the rear of the lock (**not supplied**), or through a hole under the locks base which will ensure the wires can be hidden in the floor or wall.

Finally, the correct wire gauge needs to be chosen to ensure a minimal voltage drop. The correct wire gauge is important when connecting the power wires (+ and -) to the lock as voltage drop across these wires can limit the locks operation and prematurely deplete the batteries. For all the remaining connections, a lower gauge wire can be used as these are only signal wires.

The following chart shows the appropriate wire gauge for a range of distances between the lock and power supply.

Distance (m)	AWG Size		Metric Size (mm ²)		Wire Diameter (mm)	
	12VDC	24VDC	12VDC	24VDC	12VDC	24VDC
5	24	24	0.21	0.21	0.51	0.51
10	24	24	0.21	0.21	0.51	0.51
20	22	24	0.33	0.21	0.65	0.51
30	20	22	0.52	0.33	0.82	0.65
50	18	20	0.83	0.52	1.02	0.82
100	NA	16	NA	1.31	NA	1.29

4. INSTALLATION

A typical roller door lock installation is described. The lock is being mounted on the floor while the strike will be mounted on the door to the right of the lock.

4.1 Mark the lock position

Locate the lock in the desired position and using a pen / pencil mark the three mounting hole locations through the lock base.

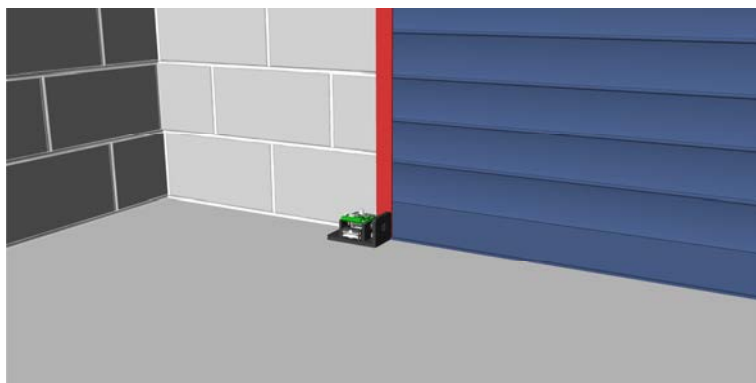

4.2 Drill the lock mounting holes

Use a M8 masonry bit to drill the three mounting holes in the concrete floor. Make the holes at least 70mm deep.

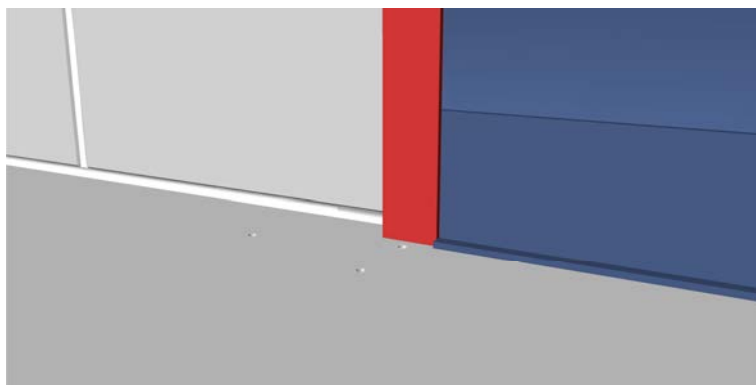
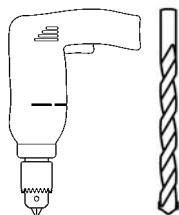

4.3 Secure the lock in position

With the lock positioned over the holes in the floor, install the three supplied Dyna bolts and tighten them.

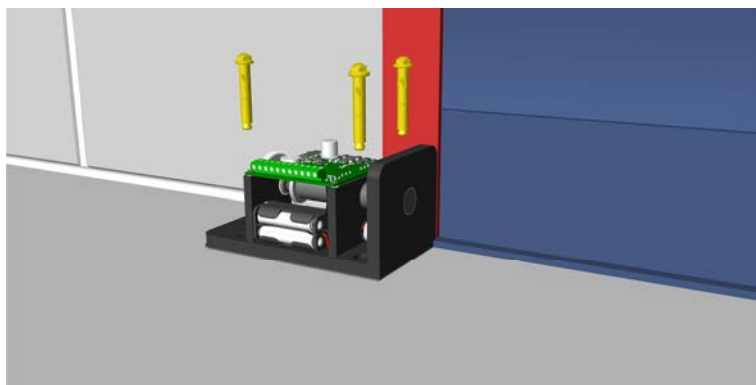

4.4 Mark the strikes position

Locate the strike in the correct position and using a pen / pencil mark the three mounting hole locations through the strike.

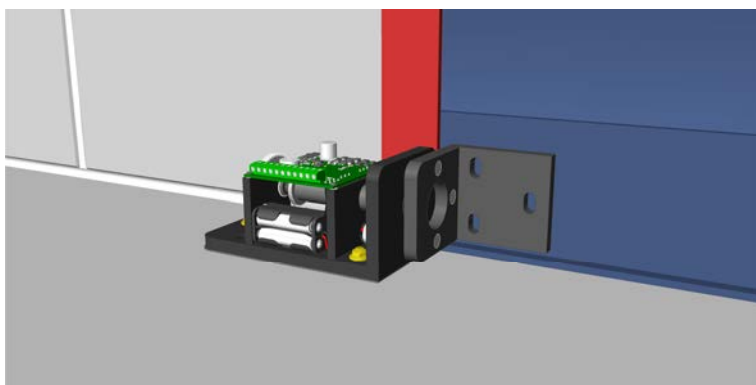

4.5 Drill the strikes mounting holes

Use a M8 drill bit to drill the three mounting holes in the door.

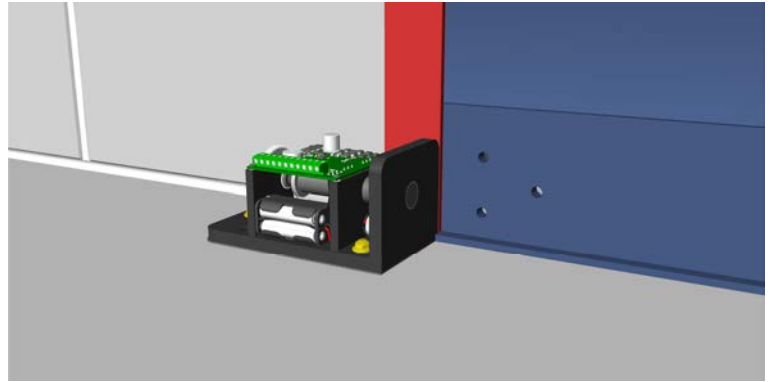
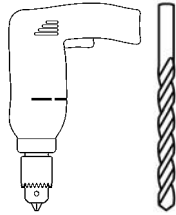

4.6 Secure the strike in position

Position the strike over the three holes and use M8 bolts / screws (not supplied) to secure it to the door.

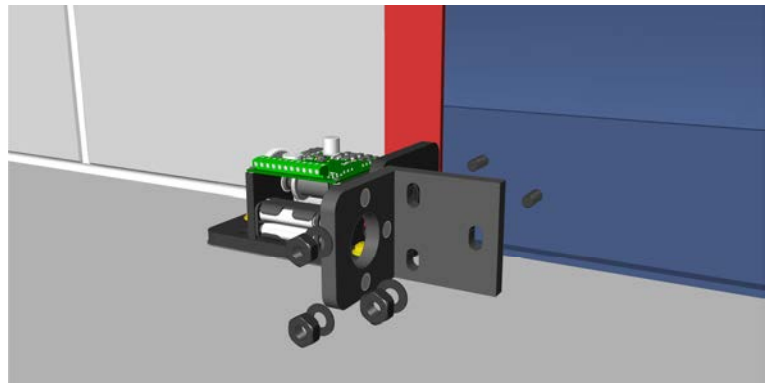

4.7 Wire the lock

Using a screwdriver and following the connection guide on the printed circuit board, connect the required wires to the lock.

Detailed wiring information can be found in section 5 - Wiring

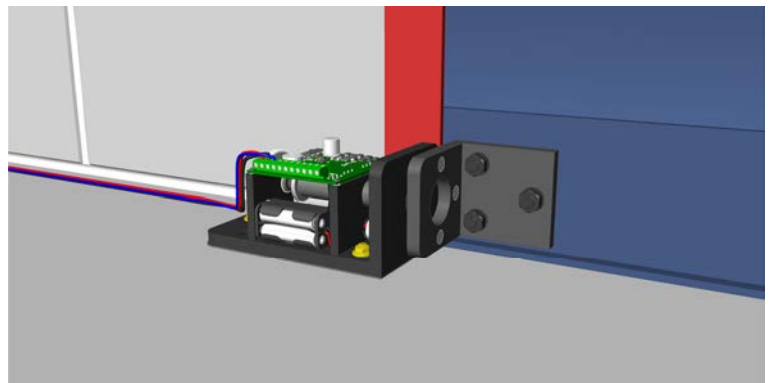

4.8 Cover the lock

Position the cover over the lock and push it down and forward. Use the keyed cam lock in the back of the cover to secure it in place.

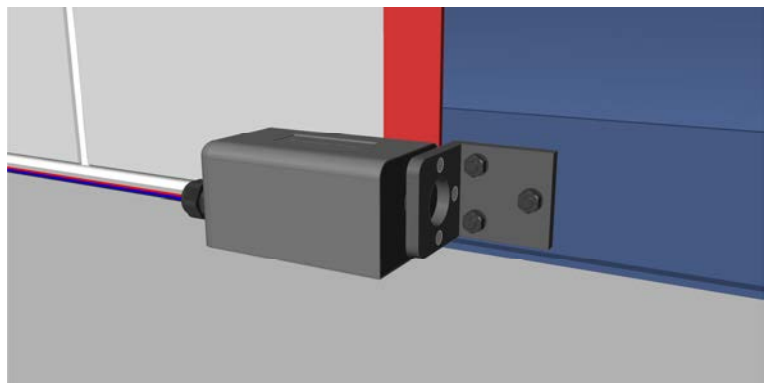

5. WIRING

Connect the YR10 as per the chart below. The three power connections are vital for the operation of the lock whilst the eight monitor connections are outputs supplied to offer feedback if desired.

+		Positive connection to DC power supply (12 – 24V)
-	Power	Negative connection to DC power supply (12 – 24V)
CL		Switched positive control input
NC	Bolt Position Switch - Unlocked	Normally closed contact of the bolt position unlocked monitor
NO		Normally open contact of the bolt position unlocked monitor
C		Common contact of the bolt position unlocked monitor
NC	Bolt Position Switch - Locked	Normally closed contact of the bolt position locked monitor
NO		Normally open contact of the bolt position locked monitor
C		Common contact of the bolt position locked monitor
NO	Door Position Switch	Normally open contact of the door position monitor
C		Common contact of the door position monitor

There are two options available when running wires into the YR10; they can be brought in through a 20mm wiring gland (**not supplied**) in the rear of the cover, or run discreetly through the hole in the locks base.

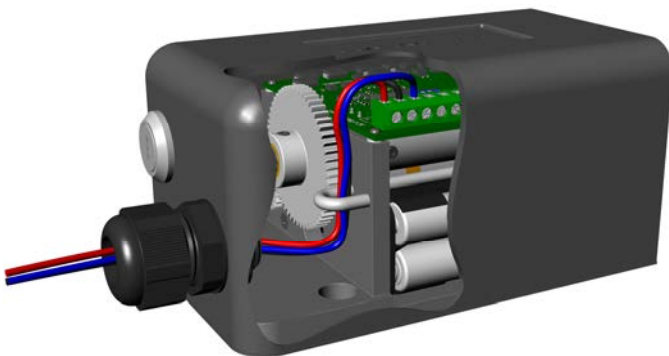

Wires run through a gland in the rear off the lock.

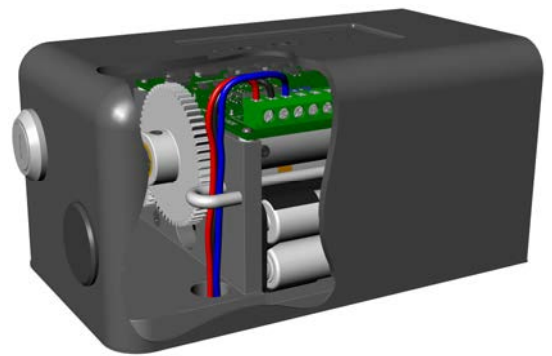

Wires run out of the hole in the base of the lock.

Running wires out of the lock via the hole in base ensures a more secure installation as the wires can be concealed in the floor or wall. If the preferred option is to use a 20mm wiring gland, a hole is available in the rear of the cover to achieve this. This hole is covered by a factory fitted blank held in place by a retaining ring that can be removed.

6. OPERATING CONFIGURATION

The operating configuration of the YR10 controls how the lock will function and there are several settings available. There are four dip switches on the printed circuit board with three being used to configure the lock and the fourth for diagnostic purposes. The dip switches are located on the top of the printed circuit board and can be set as per the following table.

1	ON	Fail Safe operation	With batteries fitted, in the event of a power failure the YR10 will unlock
	OFF	Fail Secure operation	With batteries fitted, in the event of a power failure the YR10 will lock
2	ON	Auto re-lock on	YR10 will automatically lock when the door closes
	OFF	Auto re-lock off	YR10 only locks when the user desires
3	ON	Timed re-lock on	YR10 will re-lock after one minute if an unlock signal is given and the door remains closed - Auto re-lock must also be enabled
	OFF	Timed relock off	YR10 will never re-lock if an unlock signal is given and the door remains closed
4	ON	Diagnostic mode on	YR10 goes into a service mode to output information*
	OFF	Diagnostic mode off	YR10 operates as normal

**Should only be activated in the event of a failure.*

6.1 Fail State – Switch 1

The fail state of the YR10 is determined by the selection of switch 1; however there is an additional state that can be used if desired. With no batteries installed the lock will default to Fail Maintained. In this configuration and in the event of a power failure, the lock will stay in the position it was in before the power was removed. With the batteries fitted however, selecting Fail Safe or Fail Secure ensures that the YR10 will move to that selected state if the power does fail.

6.2 Auto re-lock – Switch 2

It is recommended that Auto re-lock be ON in most installations. The ability of the YR10 to sense the doors position and automatically lock when it is closed is paramount to increasing security as it eliminates the need for the user to do so. If Auto re-lock is not selected the YR10 operates on a toggle method. In this configuration an activation of the control signal will cause the YR10 to unlock and a second activation will cause it to lock, assuming the strike is in place.

6.3 Timed re-lock – Switch 3

Timed re-lock can only be enabled when Auto re-lock has been selected and it is recommended to be ON in most installations. For increased security the YR10 has the ability to automatically lock itself after a timed period in the event of a failure of a user to do so. If an unlock signal is given to the lock but the door is not opened the YR10 can automatically lock itself again after one minute. This ensures that a door can not be left unsecured if it has been unlocked but not opened.

6.4 Diagnostic mode – Switch 4

By default the Diagnostic mode should be set to OFF. If the YR10 fails then the Diagnostic mode can be activated and information extracted from it to help determine what has caused the fault. This information needs to be interpreted by a registered distributor or the original manufacturer.

7. OPERATION

The operating scenarios detailed below stay the same regardless of whether the YR10 is configured in a Fail Safe, Fail Secure or Fail Maintained state. The state of the lock is only relevant in the event of a total power failure. Both scenarios assume that the control signal is open at the start of the operation sequence as a maintained connection will cause the lock to stay unlocked indefinitely.

7.1 Auto re-lock ON

With Auto re-lock ON selected, the momentary connection of CL to + acts as the unlock signal. Closing the door so the strike aligns with the lock and the magnet activates the internal switch, acts as the lock signal.

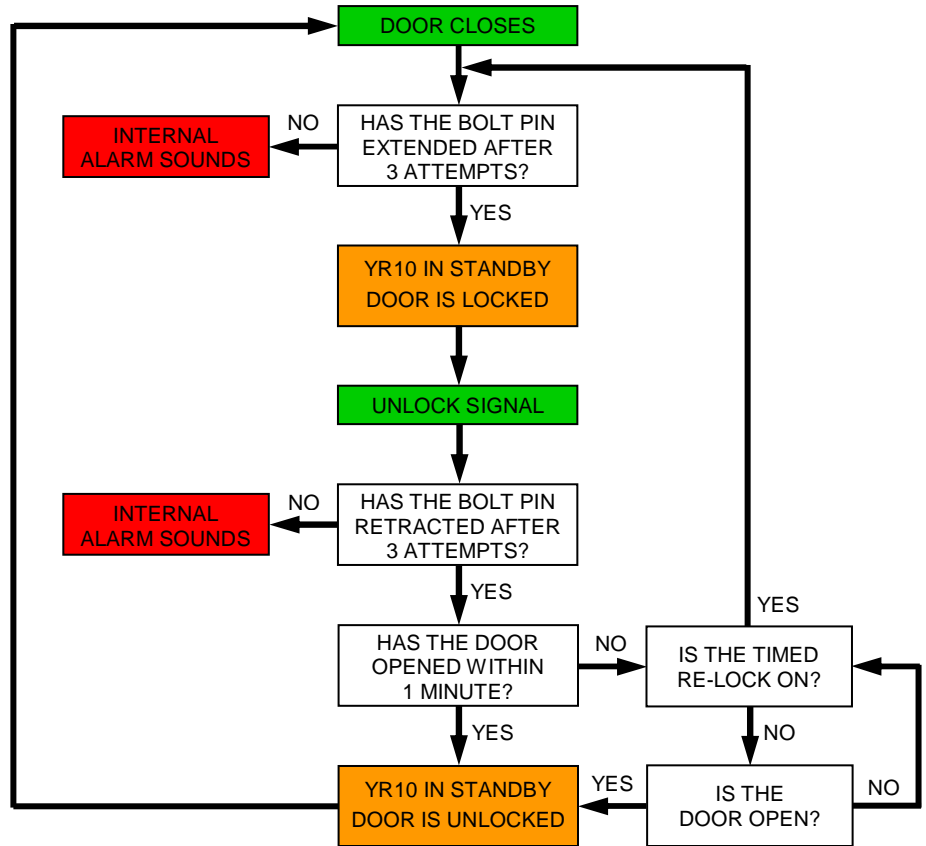

7.2 Auto re-lock OFF

With Auto re-lock OFF selected, the momentary connection of CL to + acts as both the lock and unlock signals for the YR10.

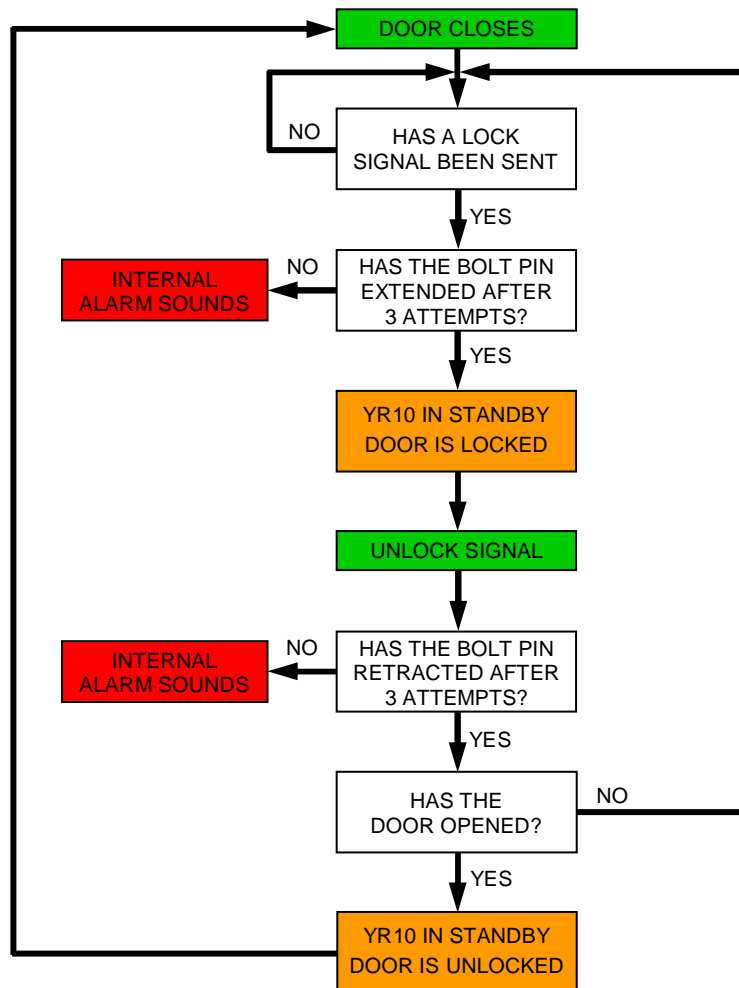

The YR10 features multiple locking / unlocking to allow for misaligned doors or unforeseen problems. If the bolt pin meets an obstruction as it is trying to secure the door, it stops and withdraws before attempting to lock again. It has a total of three attempts to secure the door after which time it will sound an alarm. The same function is present when the YR10 unlocks.

7.3 General

If the batteries are fitted and the power is removed to the YR10 at any time during its operation, the lock will revert to its pre-selected state of either unlocked or locked. The YR10 has been designed to operate with **high quality disposable alkaline batteries** and may not work correctly with alternatives. Should the batteries become flat the lock will sound an alarm to indicate a battery change is required.

If the batteries are not replaced once they have become depleted, the YR10 will automatically revert to the Fail Maintained state; i.e. in the event of a power failure the lock will stay in the position it was in before the power was removed.

The three monitors can be used to provide door and bolt position information regardless of the locks configuration.

Manual operation of the YR10 is available by removing the cover to allow access to the lock mechanism. The supplied key can be used to open and remove the cover and once access is available a screwdriver can be inserted into the centre of the large gear and turned to move the bolt pin in or out.

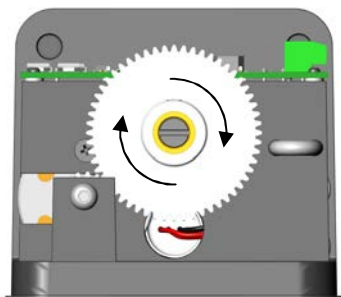

Clockwise turning of the large gear will retract the bolt pin.

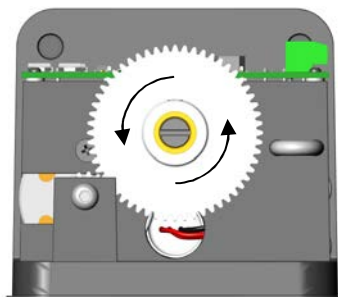

Anti-clockwise turning of the large gear will extend the bolt pin.

7.4 Alarms

To offer instant feedback about the locks state, the YR10 has an on board beeper which sounds at various times. The table below details the different alarms expected from the YR10.

Locked confirm	1 Short beep
Unlocked confirm	2 Short beeps
Failure to lock / unlock	5 Long beeps
Battery replacement	5 Short beeps sounded 5 seconds after a lock activation and repeated every 10 minutes until the batteries are replaced
Diagnostic	Various beeps – used for service

If the Failure to lock / unlock alarm has been sounded it is important that the cause of the obstruction is investigated immediately. As the alarm sounds to indicate the bolt pin has not completed its correct action, it is possible that the door is unsecured so the security of the building is at risk. Any obstruction that is identified needs to be cleared so the lock is free to operate as normal.

8. SPECIFICATIONS

Bolt Pin	Stainless Steel, \varnothing 18mm, 35mm stroke					
Lock	Die Cast Aluminium, 152mm x 88mm x 78mm					
Strike	Die Cast Aluminium, 75mm x 75mm x 70mm					
Holding Force	3000Kg (30000N)					
Power Supply	12 – 24VDC \pm 15%					
Durability	1,000,000 Operations					
Current Usage	Standby	12V < 15mA	Operation	12V < 300mA	Stall	12V < 2A
		24V < 15mA		24V < 200mA		24V < 1A
Batteries	4 x AA 1.5VDC Alkaline					
Monitor Switches	Bolt position – 60VDC, 0.2A					
	Door position – 100VDC, 0.5A					
Patent	Patent Pending					

9. DIMENSIONS

The dimensions shown are approximate and are subject to change without prior notice.

9.1 Lock

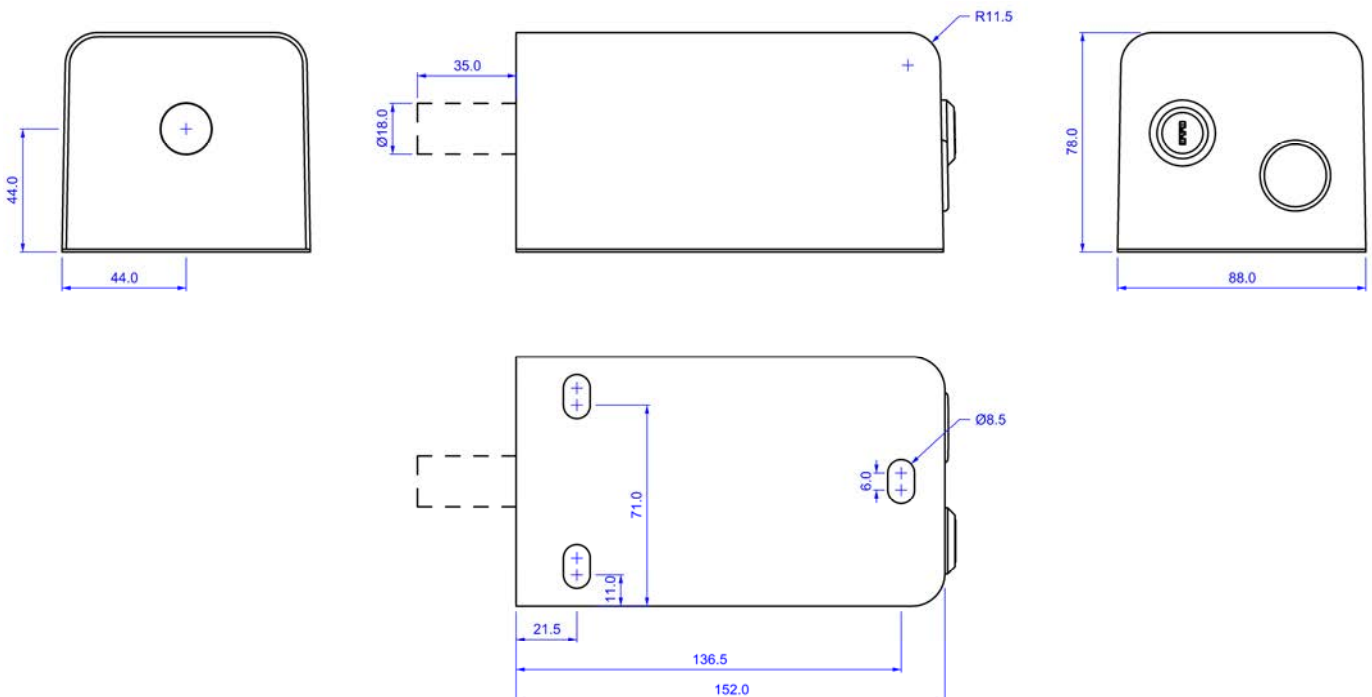

9.2 Strike

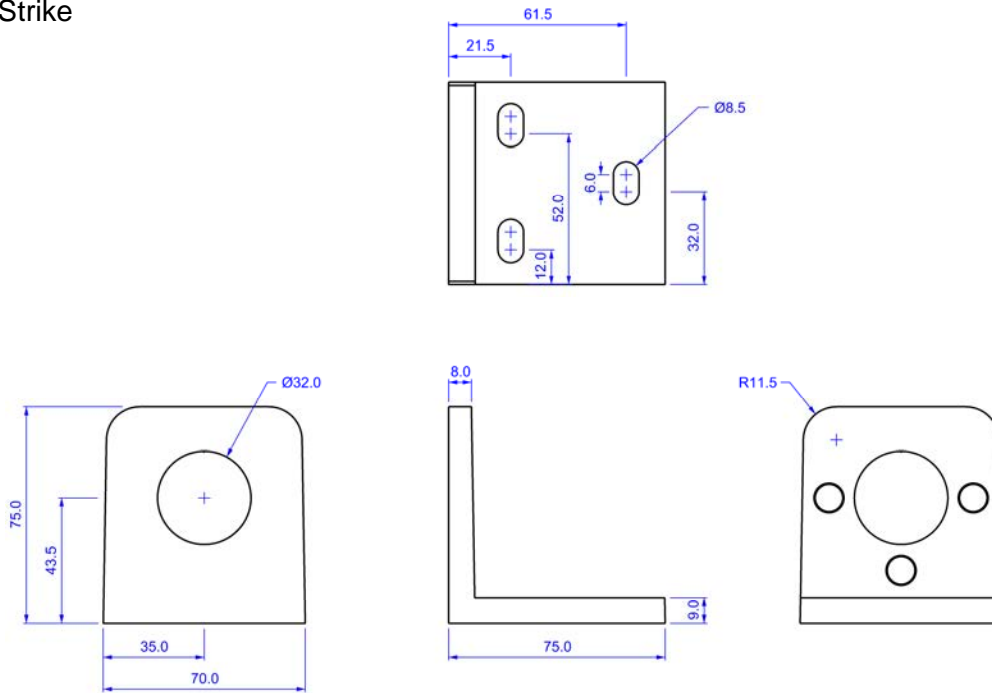

10. MAINTENANCE

The YR10 has been treated with grease and applying any other type of lubricant may void the warranty. With the cover removed it is important to take care when replacing the batteries, selecting the configuration or manually overriding the mechanism.

11. WARRANTY

The YR10 is covered with a manufacturer's 12-month warranty against faulty or malfunctioning parts, components or product. At the manufacturer's discretion, either a replacement lock or affected part will be supplied to remedy the fault. Mistreatment or ill-use of the lock may void the warranty. YNOTLOC is a trademark of Magna Electronics Pte Limited. Magna Electronics Pte Limited will not be liable for any direct, indirect, incidental or consequential loss or damage in any way related to this product.

12. UPGRADE

The YNOTLOC – Roller lock YR10 is designed and manufactured by Magna Electronics Pte Limited. Magna Electronics Pte Limited reserves the right to upgrade or change this product without prior notice.

For more information visit www.ynotloc.com